

Reflector Installation

This document provides installation instructions for the Reflector 2500 and 220 appliance hardware and software.

In this document...

This document contains the following topics:

- **Purpose 2**
- **Audience 2**
- **Requirements 2**
- **System Description 4**
- **Requesting Your Avalanche License Key 9**
- **Installing and Running Avalanche Software 9**
- **Installing the License Key File 10**
- **Viewing the License Key File 10**
- **Running in Demo Mode 11**
- **Configuring Reflector 12**
- **Shutting Down Reflector 14**
- **Related Manuals 14**
- **How to Contact Us 15**

Purpose

This installation guide provides instructions for installing and connecting Reflector 2500 and 220 appliances, as well as instructions for installing and running the Avalanche software.

Audience

This installation guide is for users of Reflector 2500 and 220 appliances.

Requirements

Reflector currently comes in two models, the 2500 and 220. The Reflector system requirements, cable requirements, PC requirements, and network connectivity are described in this section. For chassis component descriptions, refer to [“System Description” on page 4](#).

Reflector Requirements

Reflector has these system requirements:

- Standard 100-240 volt 50/60 Hz power
- A server running on the test network that supports the tested protocols
- A DNS server accessible through the administrative network, if URLs are specified using hostnames (or you must use the *Edit Hosts* feature, described in online Help under “Configuring Appliances”).

Cable Requirements

For the Reflector 2500, you will need the following customer-supplied cables:

- Ethernet Cat5 cable for the administrative port
- Depending on the NIC configuration (see [“Connector Panel” on page 6](#)), the following cables are needed for the test ports:
 - Copper: Ethernet Cat5
 - Fiber: LC.

For the Reflector 220, you will need the following customer-supplied cables:

- Ethernet Cat5 cable for the administrative port
- Ethernet Cat5 cables for the test ports.

PC Requirements

The PC on which you are installing the Avalanche software has these system requirements:

- Pentium 1.1 GHz or above
- Windows 2000 or XP Professional Edition
- Minimum of 512 MB of RAM
- SVGA 1024 x 768 resolution video or better
- Minimum of 150 MB free hard disk space
- PC with an Ethernet interface card to set up the chassis IP address
- Microsoft® Excel® 2000 (or equivalent program) to develop and view *comma separated value* (.csv) test result files.

Network Connectivity

Reflector communicates through up to five connections: one 10/100 Base-T LAN on *motherboard* (LOM) administrative port, and up to four test ports. Each of these ports is explained in the sections below and in “*Connector Panel*” on page 6.

10/100 Base-T Administrative Port

The administrative port must connect to a 10/100 Base-T network. Spirent Communications suggests that Avalanche and Reflector be connected through a switch and isolated from your production environment.



Note: All test port DNS lookups are done through the administrative port.

The administrative port can be connected to a different subnet from the test network. If Reflector overwhelms the test network, having the administrative port on a different subnet enables you to access Reflector and control the test currently running without contending with a heavily-loaded network.

Test Ports

The Reflector 2500 supports the following NIC configurations for the test ports:

- 2 dual-port copper 10/100/1000 NICs
- 2 dual-port fiber Gigabit Ethernet NICs
- 1 dual-port copper 10/100/1000 NIC and 1 dual-port fiber Gigabit Ethernet NIC (mixed media).

System Description

Reflector is a maintenance-free unit that should not be disassembled. Servicing Reflector yourself jeopardizes your warranty. The primary external components of Reflector are the network connector panel on the front and the power button on the back, both of which are addressed later in this section.

The Reflector 2500 is shown in *Figure 1*.



Figure 1. Reflector 2500

Reflector requires 2U of rackmount space (roughly 7" x 17" x 16") and ships with mounting brackets already attached, which makes rackmount installation easy by using the bolts supplied with the rack frame. Reflector can also be placed on a rack shelf.

The Reflector 220 is shown in *Figure 2*.



Figure 2. Reflector 220

Agency Compliance

The Reflector Series complies with standards published by the following agencies.

FCC

Reflector complies with the limits for a Class A digital device in accordance with Part 15 of the FCC Rules. These limits are designed to provide reasonable protection against harmful interference when this equipment is operated in a commercial environment. Operation is subject to the following two conditions:

- This device may not cause harmful interference.
- This device must accept any interference received, including interference that may cause undesired operation.

This device generates, uses, and can radiate radio frequency energy if not installed and used in accordance with the instructions in this manual. Operating this equipment in a residential area is likely to cause harmful interference, and the customer will be required to rectify the interference at his or her own expense. This product requires the use of external shielded cables to maintain compliance pursuant to Part 15 of the FCC Rules.

CE

The CE symbol on the product label (on the back of the box) indicates this network appliance is compliant with the EMC Directive and Low Voltage Directive of the European Union. This product meets the following technical standards:

- EN 55022 — “Limits and Methods of Measurement of Radio Interference Characteristics of Information Technology Equipment.”
- EN 60950 — “Safety of Information Technology Equipment.”

TUV

This product carries the cTUVus mark.

GS

This product carries the GS mark.



VORSICHT!

Explosionsgefahr bei unsachgemäßem Austausch der Batterie.

Ersatz nur durch denselben oder einen vom Hersteller empfohlenen gleichwertigen Typ.

Entsorgung gebrauchter Batterien nach Angaben des Herstellers.



Warning: Risk of explosion if battery is replaced by an incorrect type. Dispose of used batteries according to instructions.

Connector Panel

The Reflector 2500 connector panel, horizontal (*Figure 3*) or vertical (*Figure 4*) configuration, can take up to five *network interface card* (NIC) connectors: one 100/1000 Base-T *LAN on motherboard* (LOM) administrative port, and four test ports (numbered 0-3 in *Figure 3* and *Figure 4*) in the following NIC configurations:

- 2 dual-port copper 10/100/1000 NICs
- 2 dual-port fiber Gigabit Ethernet NICs
- 1 dual-port copper 10/100/1000 NIC and 1 dual-port fiber Gigabit Ethernet NIC (mixed media).



Warning: The mixed media configuration comes installed with the copper NIC on the top (*Figure 3*) or left (*Figure 4*), and the fiber NIC on the bottom (*Figure 3*) or right (*Figure 4*). Please do not physically change the NICs. Contact Spirent Communications Technical Support for any issues regarding the physical configuration. (Refer to *page 15* for contact information.)



Figure 3. Reflector 2500/2200 Horizontal Connector Panel

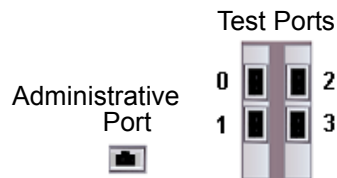

Figure 4. Reflector 2500/2200 Vertical Connector Panel

The network data cables connected to these ports must be as follows:

- Ethernet Cat5 for the administrative port
- Depending on the NIC configuration, the following for the test ports:
 - Copper: Ethernet Cat5
 - Fiber: LC.

The mouse, keyboard, and printer connectors should not be used.

Power Supply

The power supply for the Reflector 2500 (see [Figure 5](#)) is located on the bottom left back of the unit and is controlled by the power button. The power button is located to the right of the power supply fan.



Tip: Plug Reflector 2500 into a surge-protected outlet to protect it from electrical surges.

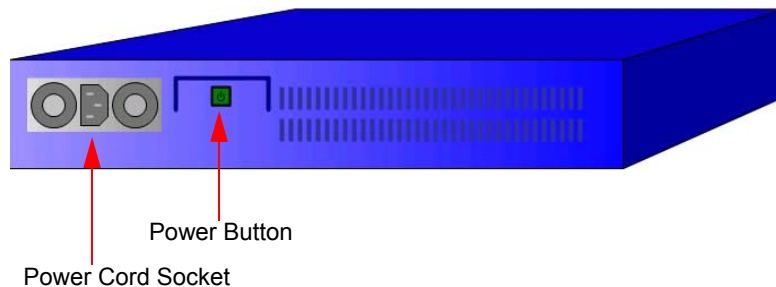

Figure 5. Reflector 2500 Power Button

The power switch for the Reflector 220 is shown in [Figure 6](#). Always use the power switch to turn off the system before connecting the power cord.

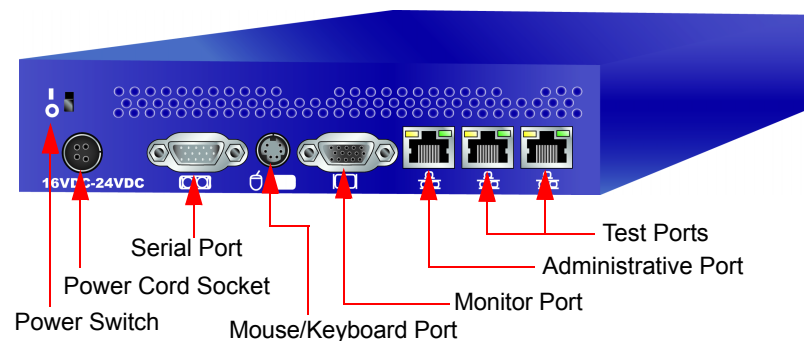

Figure 6. Reflector 220 Power Switch

Rack Mounting Considerations

Reflector mounts in a standard 19" (48 cm) equipment rack. This product may require safety agency evaluation, certification, and licensing. Check with your building inspector for requirements applicable to your location.



To remove the mounting brackets:

- 1 Place the Reflector unit on a sturdy table or desk.
- 2 Remove the bolts securing the mounting bracket to the unit (as shown in *Figure 7*).
- 3 Replace all the bolts in the original holes, then tighten all the bolts.
- 4 Repeat these steps to remove the other bracket, taking into account a mirrored location on the bolts shown.

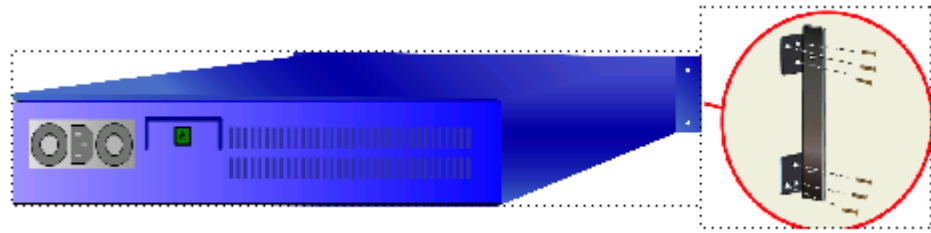

Figure 7. Bracket Removal

Connecting Reflector

Reflector connects and operates through your local network much like a standard PC. It boots with the IP address and subnet mask: 192.168.42.3/255.255.255.0.



To connect Reflector:

- 1 Configure a laptop or workstation with the IP address and subnet mask:
192.168.42.1/255.255.255.0.
- 2 Connect the laptop or workstation to Reflector's administrative port with a cross-over cable or through a (preferably full-duplex) network switch or hub (*Figure 8*).

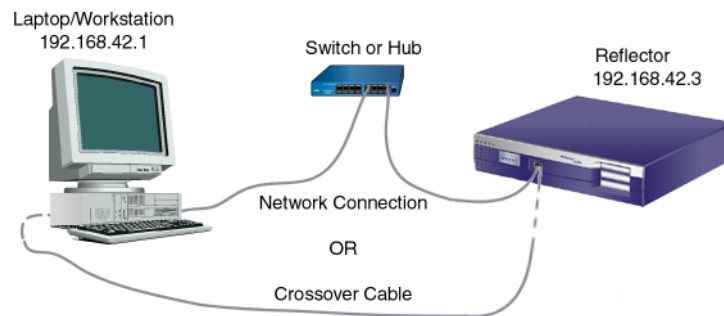

Figure 8. Reflector's Administrative Port

- 3 To turn on the Reflector 2500, press and hold the power button (*Figure 9 on page 9*) for 3 seconds. For the Reflector 220, turn on the power switch. For either model, wait 2-3 minutes for the unit to fully start up.

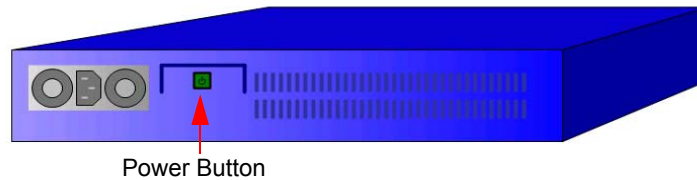

Figure 9. Reflector 2500 Power Button

Requesting Your Avalanche License Key

You must obtain and install a valid Avalanche license key before you can use Avalanche software. License keys are provided by Spirent Communications Technical Support. See *“How to Contact Us”* on page 15 for service hours and contact information.

Installing and Running Avalanche Software

Avalanche software and related utilities can be downloaded from the Spirent Communications Customer Service Center website or from the CD shipped with your order. You use the Avalanche Commander GUI to establish a connection and configure your appliance.

To Install the Avalanche Commander

Run the Avalanche installation program on your PC, and follow the instructions in the InstallShield Wizard.



Note: When you uninstall the Avalanche (via Add/Remove Programs on your PC), additional files may be left in the installation directory. The uninstaller only removes those files explicitly installed by the installer, and does not remove any additional files or directories created after installation.

To Run the Avalanche Commander

Select the **Start > Programs > Spirent Communications > Avalanche > Avalanche Commander** menu item on your PC (Figure 10), or double-click the **Avalanche Commander** icon on your desktop.

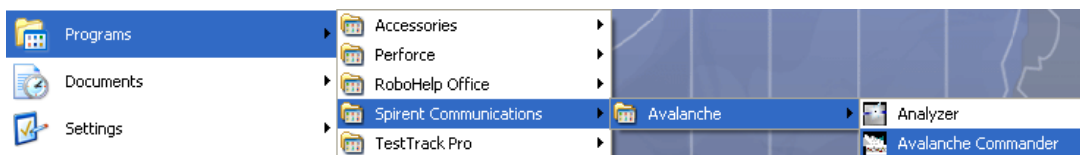

Figure 10. Avalanche Commander Startup

Installing the License Key File

After you have installed Avalanche on your PC you must install the license key file that enables you to use Avalanche with your appliances.



To install the license key file:

- 1 Run the Avalanche Commander, and select **Administration > Load License...** from the menu bar to display the Load License window (*Figure 11*).

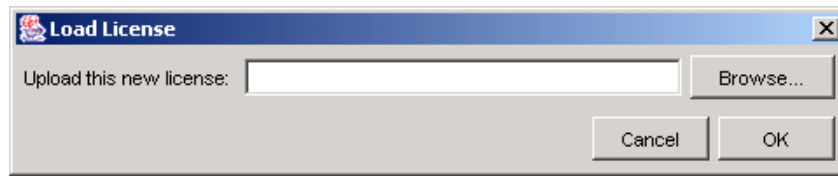

Figure 11. Load License Window

- 2 Click **Browse...** to find the license file provided by Spirent Communications.
- 3 Click **OK**.



Note: Failure to perform this step will limit your test duration to 100 seconds.

You are ready to configure your appliances for Avalanche testing. (See “*Configuring Reflector*” on page 12 for more information.)

Viewing the License Key File

To locate information on the license key, use the following procedure.

To View the Current License Key File

Run the Avalanche Commander, and select **Administration > View License...** from the menu bar. The View License window (*Figure 12 on page 11*) is displayed. Any errors regarding the license will be displayed in this window.

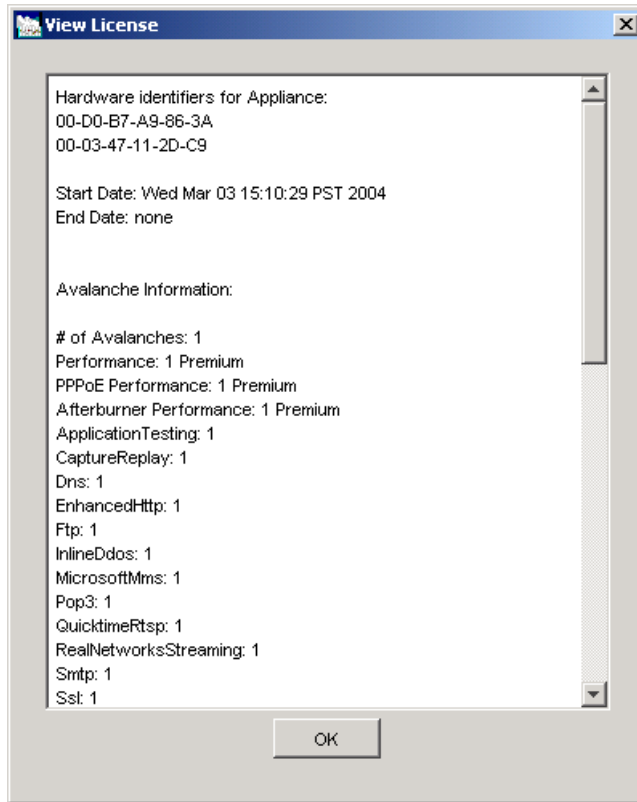

Figure 12. View License Window

Running in Demo Mode

You can run the Avalanche software in demo mode, if you do not have a valid license file. In this mode, your test duration will be limited to 100 seconds when a test is run. (A warning message appears while running in demo mode.)

When you start the Avalanche software, the License Error pop-up window will be displayed if you do not have a valid license file. This window gives you the option to run in demo mode, as shown in [Figure 13 on page 12](#).

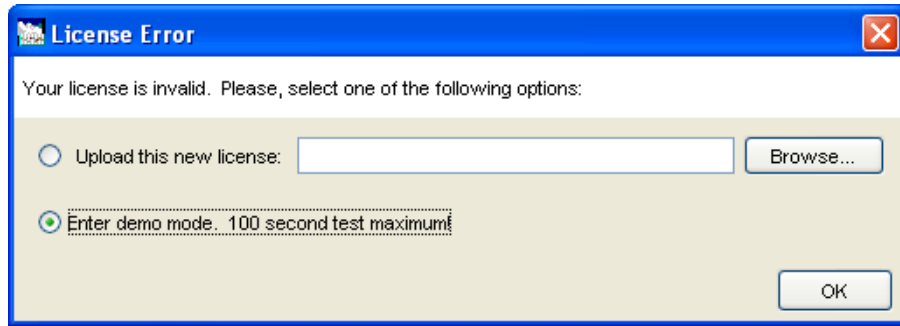
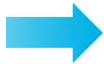

Figure 13. License Error Window

Configuring Reflector



To configure Reflector:

- 1 Select **Administration > Appliances...** from the menu bar (*Figure 14*).

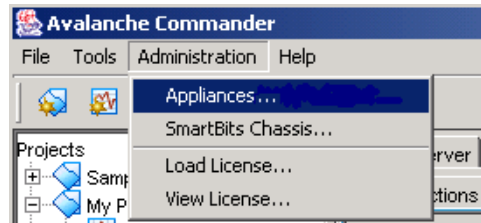

Figure 14. Avalanche Commander Administration Menu

The Appliance Administration window is displayed (*Figure 15*).

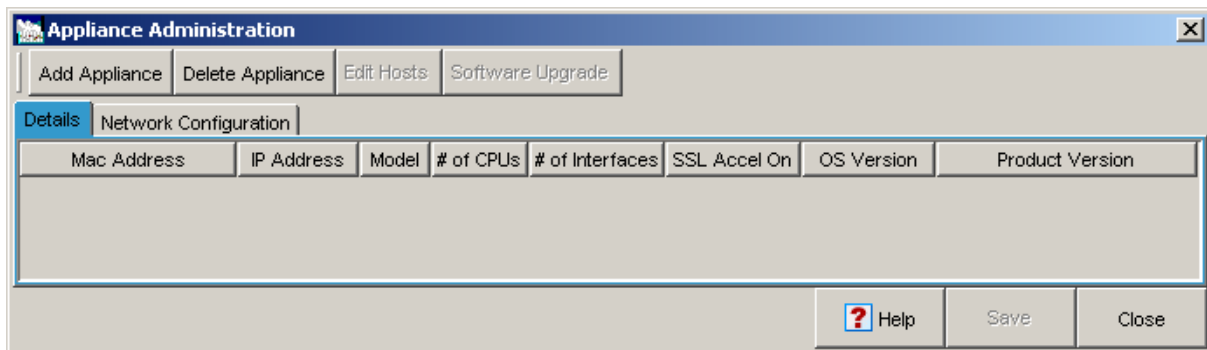

Figure 15. Appliance Administration Window

- Click the **Add Appliance** button. You will be prompted to enter an IP address for the appliance that you want to add (*Figure 16*). Enter the factory default IP address for Reflector, **192.168.42.3**, and click **OK**.

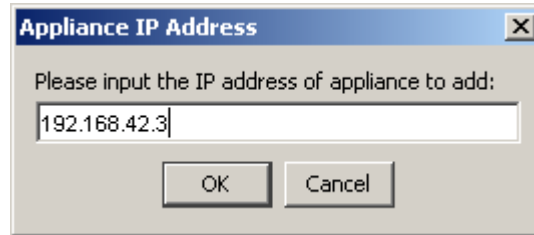

Figure 16. Appliance IP Address Prompt

Once successfully added, a new row for this appliance appears in the *Details* tab of the Appliance Administration window (*Figure 17*). All fields in this tab are read-only.

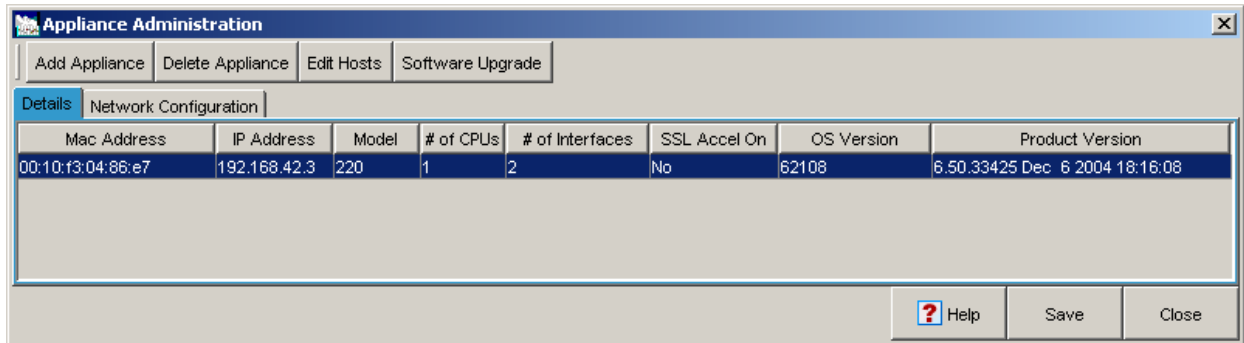

Figure 17. Details Tab with New Row

- To customize the IP address for the appliance’s administrative port, click the **Network Configuration** tab, select the **IP Address** field, and enter the desired IP address (*Figure 18*). Edit the other fields, as required, to configure the appliance. (For details on the configurable fields, refer to online Help under “Configuring Appliances.”)

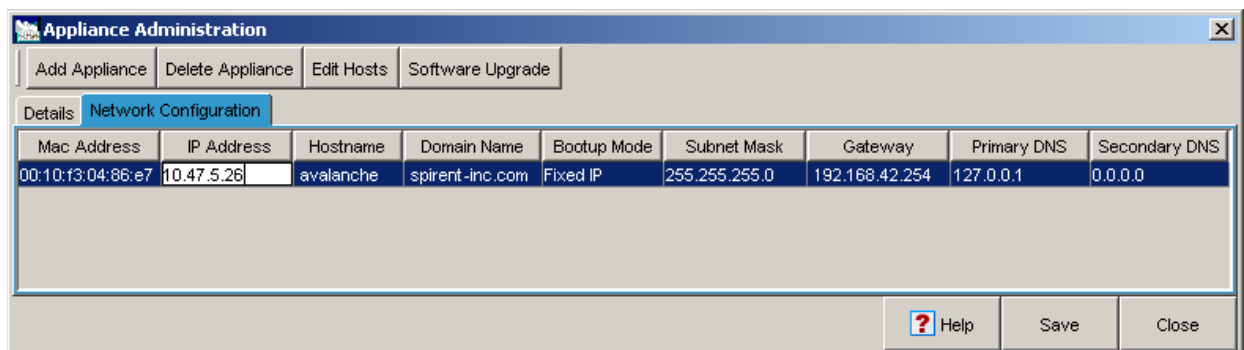

Figure 18. Network Configuration Tab



Note: The choices for *Bootup Mode* include *Fixed IP* or *DHCP*. If you select *Fixed IP*, you need to manually enter the *IP Address*, *Subnet Mask*, default *Gateway*, *Primary/Secondary DNS* server, and *Domain Name*. If you select *DHCP*, these fields will be determined for you.

- 4 Click the **Close** button at the bottom of the Appliance Administration window. You will be prompted to save your configuration settings if there are unsaved changes, and the appliance on which you made changes will be rebooted. Wait 2-3 minutes for the unit to fully start up.
- 5 Disconnect the cable from the appliance's administrative port and reconnect as appropriate for your new network configuration settings. Ensure that your laptop or workstation running Avalanche Commander has access to the appliance.
- 6 Select **Administration > Appliances...** from the menu bar, and click the **Network Configuration** tab. Confirm your appliance configuration settings, and click **Close** to exit.

Shutting Down Reflector

To shut down the Reflector 2500, press and hold the power button on the back of the unit for three seconds.

To shut down the Reflector 220, turn off the power switch on the back of the unit.

Related Manuals

Additional documentation and manuals related to this Reflector Installation guide are listed below.

- *Avalanche Release Notes* – Contain information that may affect product installation, test configuration, or test results, including last-minute requirements or product changes. It is highly recommended that you view all Release Notes before you install or use Avalanche and Reflector appliances.
- *Avalanche online Help* – Provides information on all procedures required to prepare your testing environment for Avalanche tests using Avalanche and Reflector appliances, as well as TeraMetrics modules within a SmartBits chassis.
- *Avalanche Analyzer User Guide* – Describes the Avalanche Analyzer user interface, which allows you to view test results files.

How to Contact Us

Technical support is available Monday through Friday between 06:00 and 18:00 Pacific Time.

To obtain technical support for any product, please contact our Technical Support Department using any of the following methods:

U.S.

E-mail: support@spirentcom.com

Web: <http://support.spirentcom.com>

Toll Free: 1-800-SPIRENT (1-800-774-7368)

Phone: + 1 818-676-2616

Fax: +1 818-880-9154

Europe

E-mail: support.europe@spirentcom.com

Web: <http://support.spirentcom.com>

Phone: +33 (0) 1 61 37 22 70

Fax: +33 (0) 1 61 37 22 51

In addition, the latest versions of user manuals, application notes, and software and firmware updates are available on the Spirent Communications Customer Service Center website at <http://support.spirentcom.com>.

Company Address

Spirent Communications, Inc.
26750 Agoura Road
Calabasas, CA 91302
USA

